

TERMINAL PART ASSY

CONTROLLED COPY
 Issued Date
 29 OCT 2010
TECHNICAL DIVISION
SCI

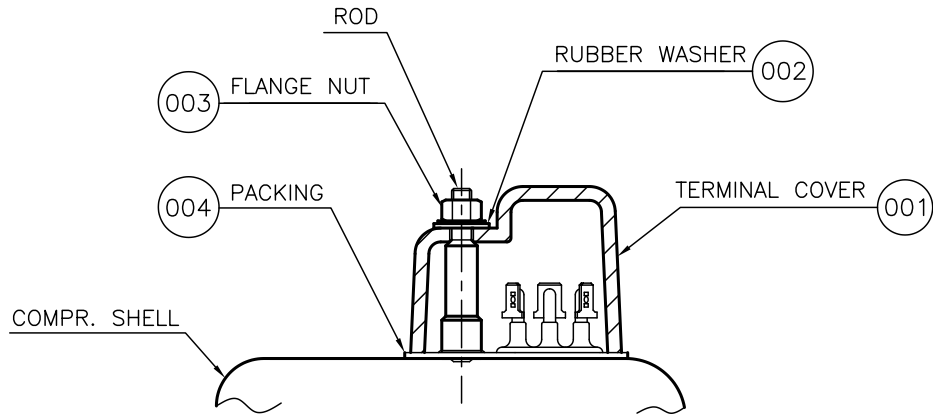
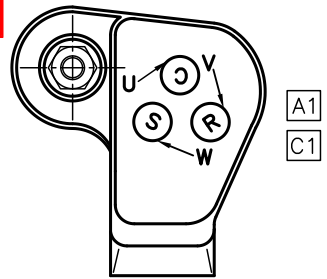
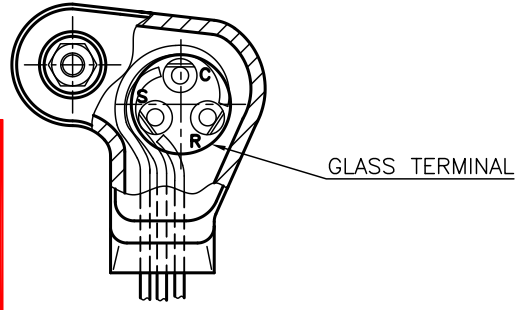

001 TERMINAL COVER

E1 SPECIAL NOTE
 THE PART SHOULD NOT CONTAIN PROHIBITED SUBSTANCES AND DETAIL SHOULD COMPLY WITH SCI-RoHS & REACH[SVHC] SUBSTANCE LIST. (STD100001)

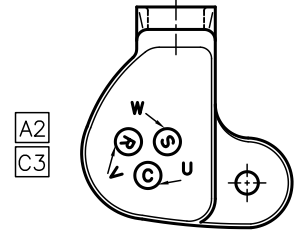
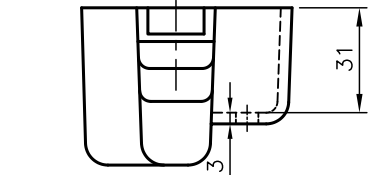
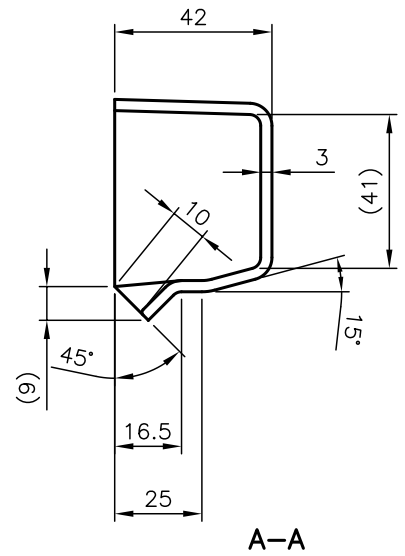
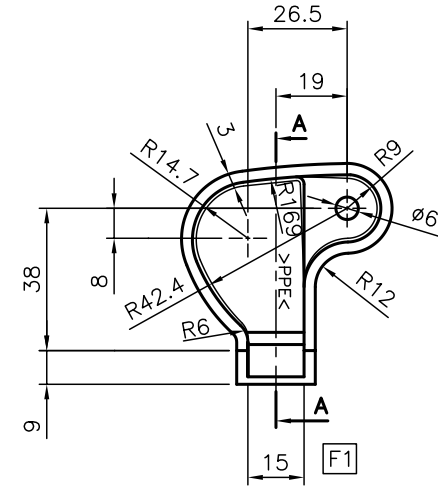

NOTES 1. MATERIAL : POLYPHENYLENE ETHER
 D1 E2 XYRON 500Z or
 NORYL PX9406P
 2. THICKNESS : 3 mm.

CR25C138H03

CHANGE
 F1 (B-5)
 DRAWING WAS AS BELOW.

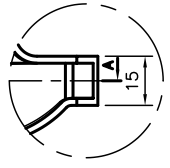

10-10-28
 C.PEERAYOOT
 S.DUMRONGSAK
 F

USE FOR MODEL
 S
 R
 T
 P
 N
 A
 B

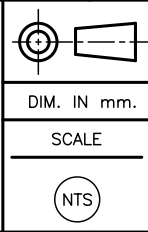

 SIAM COMPRESSOR INDUSTRY MITSUBISHI ELECTRIC GROUP		DATE	03-01-09	APPROVED
		DRAWN	N.TUM, K.NATHANICHA	S.DUMRONGSAK
CHECKED	J.SANTICHAJ			
DESIGNED	C.PEERAYOOT			

TITLE		TERMINAL PART ASSY	
DWG. NO.		SC01D024	1/3

002 RUBBER WASHER

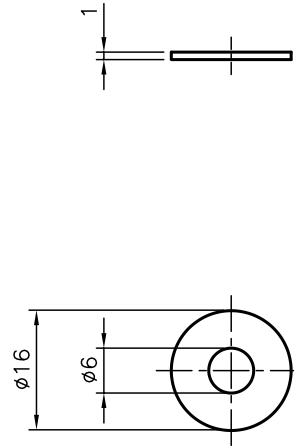

CONTROLLED COPY
 Issued Date
 29 OCT 2010
TECHNICAL DIVISION
SCI

NOTES 1. MATERIAL : CHROLOPLENE RUBBER BLACK
 2. HARDNESS : Hs 60

CR34D115H01

003 FLANGE NUT

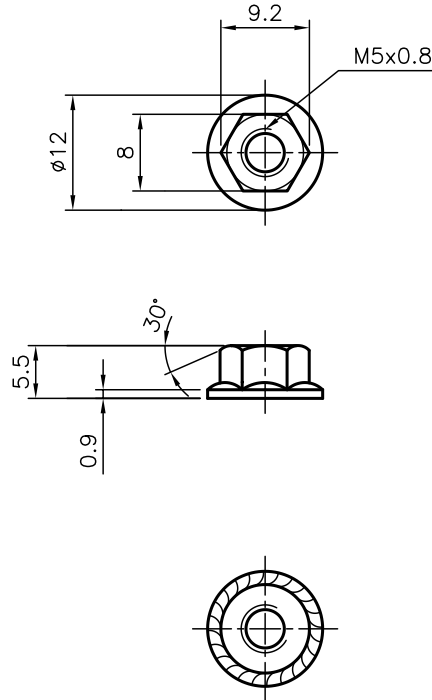

NOTES 1. MATERIAL : SWCH6R
 2. CORROSION PROTECTION : FINISH SILVER

SC12D378H01

004 PACKING

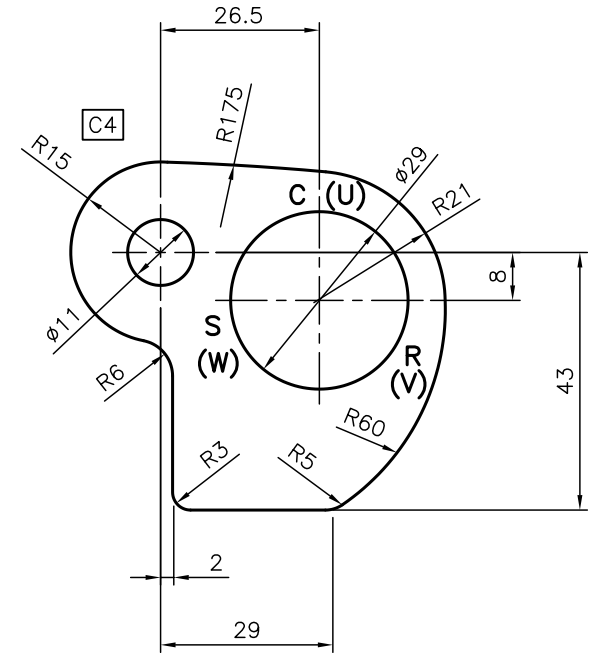

NOTES 1. MATERIAL : ETHYLENE PROPYLENE RUBBER (BLACK)
 2. THICKNESS : 1.5 mm.

CR34D377H01

D

CHANGE

USE FOR MODEL

- S
- R
- T
- P
- N
- A
- B

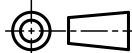

DIM. IN mm.

SCALE

NTS



SIAM COMPRESSOR INDUSTRY
 MITSUBISHI ELECTRIC GROUP

DATE	03-01-09
DRAWN	N.TUM, K.NATHANICHA
CHECKED	J.SANTICHAJ
DESIGNED	C.PEERAYOOT

APPROVED

S.DUMRONGSAK

TITLE

TERMINAL PART ASSY

DWG. NO.

SC01D024

2/3

CHANGE

CHANGE

A1 (B-2)
WAS ADDED U,V,W.
A2 (C-4)
WAS ADDED U,V,W.
03-01-09
S.DUMRONGSAK
P.PAISARN

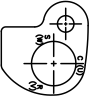
CHANGE
C4 (B-5)

WAS

PART CODE WAS CHANGE
(CR12D116H01) TO
(SC12D378H01).
06-01-19
W.SUNPET
S.DUMRONGSAK

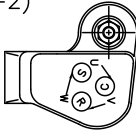
06-11-06
J.SANTICHAJ
I.KORAKOT (FOR)

C1 (B-2)

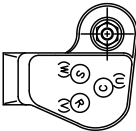
WAS

D1 (C-5)
D1 WAS XYRONG702V.
08-03-07
J.SANTICHAJ
I.KORAKOT (FOR)
(NO. NCQ081687)

WAS

E1 (A-5)
SPECIAL NOTE WAS
CHANGE.

C2 (C-3)
NOTES WAS ADDED.
C3 (C-4)

E2 (C-6)
NOTES 1. MATERIAL
: POLYPHENYLENE
ETHER XYRON 500Z.
E3 FORM WAS
CHANGE.
10-09-21
J.SANTICHAJ
S.DUMRONGSAK
(NO. NCQ10I0161)

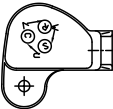
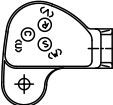

WAS

CONTROLLED COPY
Issued Date
29 OCT 2010
TECHNICAL DIVISION
SCI

CHANGE

USE FOR MODEL

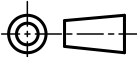
- S
- R
- T
- P
- N
- A
- B



DIM. IN mm.	DATE	03-01-09	APPROVED
SCALE	DRAWN	N.TUM, K.NATHANICHA	S.DUMRONGSAK
NTS	CHECKED	J.SANTICHAJ	
	DESIGNED	C.PEERAYOOT	

TITLE		TERMINAL PART ASSY	
DWG. NO.		SC01D024	3/3